

# Warning

A warning indicates a potentially hazardous situation which, if not avoided, could result in death or serious injury.

1. Read all instructions and save them for later reference.
2. Follow all warnings and instructions marked on the product.
3. Do not stand on the carrier.
4. Do not ride any vehicle during loading.
5. Store the B-Dawg carrier in a safe place.
6. Do not exceed vehicle tongue weight rating.
7. Only use with class III hitch.  
Most class III hitches limit total hauling capacity to 500 lbs.
8. Improper use of carrier could result in death or serious injury.
9. Do not put the carrier onto a 5th wheel trailer or any other kind of trailer.
10. **Carrying capacity is limited to 600 lbs. max. Your vehicle suspension and hitch may limit the hauling capacity of the carrier.** For more information on vehicles and hauling capacities, visit [www.versahaul.com](http://www.versahaul.com)

## Manufacturer Information:

BNK, Inc.  
9341 S. St. Rd. 39  
Winamac, IN 46996  
(888) 818-9915

Product Name: B-Dawg Double Motorcycle Carrier  
Product Description: Double aluminum motorcycle carrier  
Model Number(s): BD-Double

Serial number \_\_\_\_\_  
(please fill in serial number affixed to the carrier)

# B-Dawg Double Motorcycle Carrier Instruction Booklet

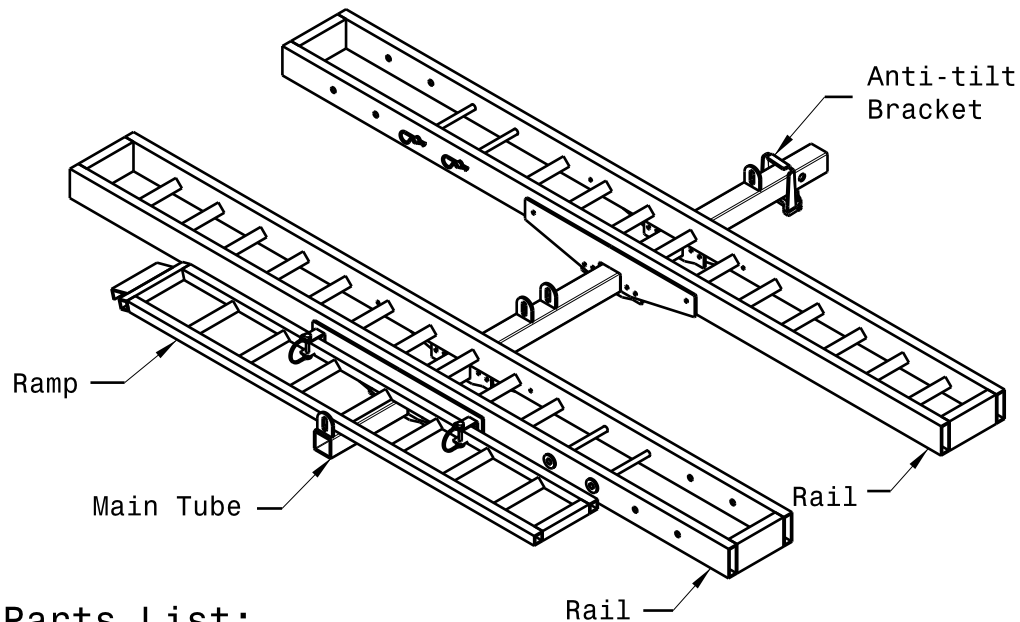

## Parts List:

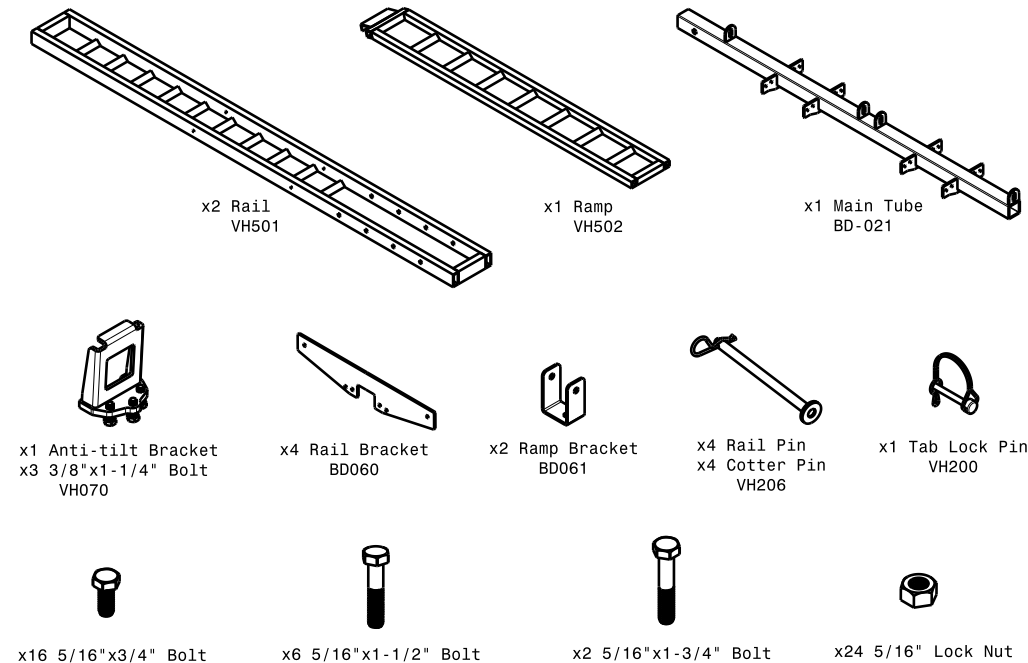

### STEP 1

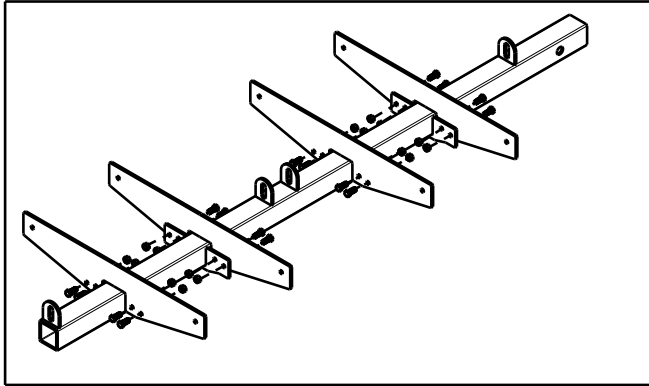

Mount the Rail Brackets to the Main Tube by using the 5/16"x3/4" Bolts and Lock Nuts. Do not tighten, leave the bolts loose for now.

### STEP 2

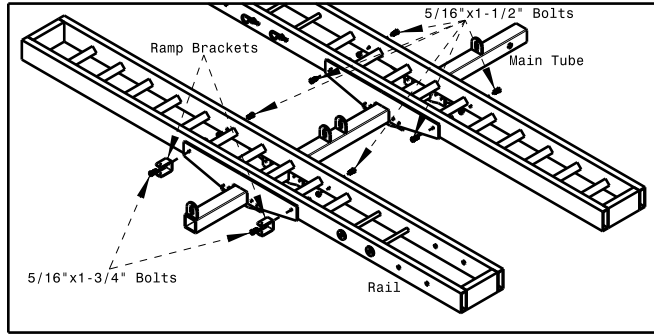

Secure the Rails to the Main Tube and the Ramp Brackets to the indicated Rail using (6) 5/16"x1-1/2" Bolts and (2) 5/16"x1-3/4" Bolts where shown in the figure above. Secure and tighten all Bolts with Lock Nuts (including those from Step 1). The side of each Rail with the empty slot will be where the front tire of each bike sits.

### STEP 3

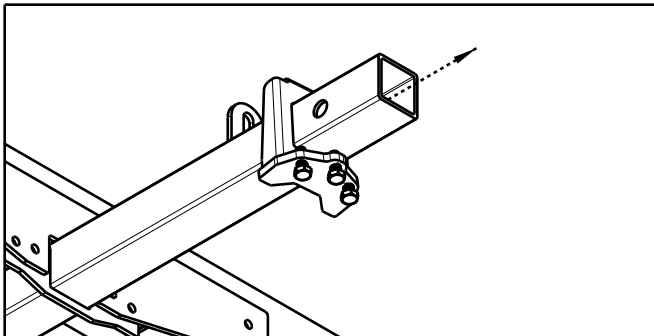

Insert the Anti-tilt bracket onto the Main Tube and insert the carrier into your hitch receiver. After securing the carrier with your hitch pin, push the Anti-tilt bracket against your hitch collar and tighten the 3/8" bolts. Loosely tighten the center bolt first to ensure that it fits just behind the lip of the hitch collar before tightening the side bolts. This prevents the bracket from slipping on rounded hitch collars. After tightening the sides, finish tightening the center bolt.

### STEP 4

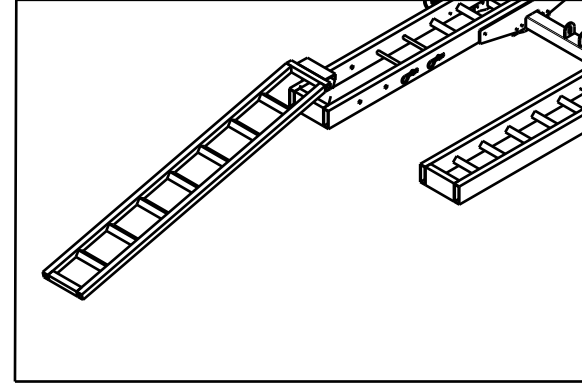

To load your bike, mount the ramp onto the side of the rail as shown.

### STEP 5

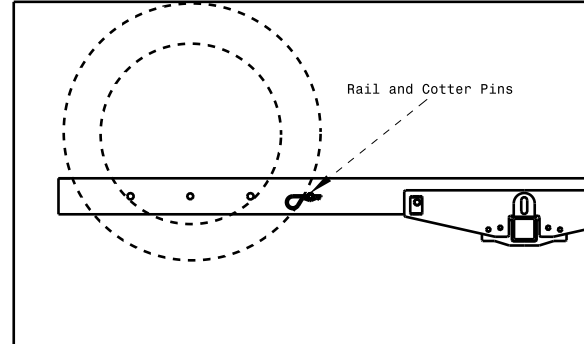

Insert the Rail Pin into the appropriate hole for your specific tire size, such that your bike's tire is supported and resting on the rail. Lock the Rail Pin with the Cotter Pin.

### STEP 6

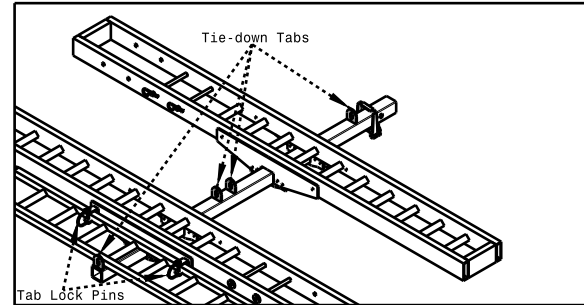

Secure the Ramp on the carrier using the Tab Lock Pins when it is not being used. Secure your bike with straps (not provided) using the Tie-down Tabs as shown.