



PARTS

Note: B-Dawg carriers are attached with your standard Hitch Pin (not included).



(1) 5" Cargo Basket Bottom

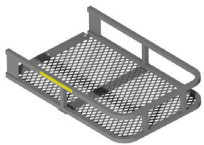

(1) 5" Cargo Basket Top



(2) Joint Plate



(2) Support Beam



(1) Main Tray Tube



(1) Hitch Tube



(2) M10 x 90 Bolt



(1) M10 x 80 Bolt



(4) M10 x 30 Bolt



(14) M10 Flat Washer



(7) M10 Lock Washer



(7) M10 Nut



(12) M6 x 20 Bolt



(24) M6 Flat Washer



(12) M6 Lock Washer



(12) M6 Nut



(1) 5/8" x 3 3/4" Bolt



(2) 5/8" Flat Washer



(1) 5/8" Lock Washer



(1) 5/8" Nut



(1) 5/8" Brass Pin



(1) Cotter Pin



(2) Reflective Sticker

TOOLS



(2) Adjustable Wrench

WARNING

To avoid risk of injury to yourself and others on the highway and/or property damage, read and follow all instructions accompanying this product as well as specific warnings regarding weight limits, loading and handling, and roll over risks contained in your Vehicle Owner's Manual and the Hitch Manufacturer's Manual.

- Carrier hitch pin and cotter pin must be secured before each use.
- Distributed load must not exceed the hitch manufacturer's tongue weight rating or the vehicle manufacturer's rear load limit.
- Do not stand on the carrier.
- Do not block taillights, safety equipment, or exhaust pipes.
- Do not transport flammable/combustible items on carrier.
- Only use with a Class 3 or 4 hitch. Most Class 3 hitches are limited to 500 lbs. total hauling capacity.
- Do not put the B-Dawg carrier onto a 5th wheel trailer or any other kind of trailer.

LIMITED WARRANTY

The Limited Warranty on the B-Dawg Carrier.

EZRA DISTRIBUTING, INC warrants the carrier and related components. This warranty applies to any part found to be defective due to material and/or workmanship when inspected at the factory of Ezra Distributing, Inc. in Winamac, IN. Ezra Distributing, Inc. will, at its option, repair or replace defective parts to the original purchaser at no charge other than transportation. Sales receipt as proof of date of purchase is required, which will be returned. Ezra Distributing, Inc. assumes no liability for labor charges made in performance of this warranty.

The warranty periods are as follows from date of purchase:

CARRIER FOR 1 YEAR, VOID IF: frame is broken or bent due to abuse (example: underside scraped abusively).

ALL WARRANTIES ARE VOID IF: the carrier has been rented, used under abnormal conditions, or subjected to abuse, misuse, neglect, or improper maintenance.

All warranties should be handled at point of purchase unless other arrangements are made.

Ezra Distributing, Inc. is not liable for any damage claim or liability claim, personal or otherwise resulting from operation of this carrier in any way. All transportation charges for items returned for warranty evaluation and/or replacement are to be borne by the customer.

For one (1) year from the date of purchase, Ezra Distributing, Inc. will repair or replace for the original purchaser, without charge, any part or parts manufactured by Ezra Distributing, Inc. and found, upon examination at our factory in Winamac, to be defective in materials and/or workmanship.

All transportation charges on parts submitted for replacement under this warranty must be borne by the purchaser. This warranty does not apply to parts not manufactured by Ezra Distributing, Inc. Their manufacturer may warrant these items. This warranty does not apply to any part which has been damaged by accident, alteration, abuse, improper adjustment, normal wear, or any other cause beyond our control.

Use of replacement parts other than genuine Ezra Distributing, Inc. parts may impair the safety of your machine and void this warranty.

IMPORTANT

THIS WARRANTY IS VOID UNLESS THE PRODUCT REGISTRATION CARD IS FILLED OUT COMPLETELY AND RETURNED TO THE FACTORY AT WINAMAC, INDIANA WITHIN TEN (10) DAYS OF PURCHASE.

OUR WARRANTY COVERS OUR PRODUCT FOR ONE YEAR. WE ARE NOT ABLE TO EXCHANGE USED B-DAWG CARRIERS FOR REFUNDS OR NEW CARRIERS.



STEP 1

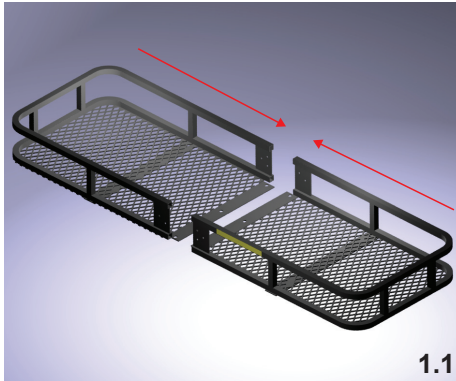

Place the two Cargo Baskets end to end, overlapping the centers (Figure 1.1).

Use a Joint Plate on the outside of each overlapping end to connect the baskets with Bolt Assembly A (six per plate). Bolt Assembly A consists of (1) M6 x 20 Bolt, (2) M6 Flat Washers, (1) M6 Lock Washer, and (1) M6 Nut (Figure 1.2).

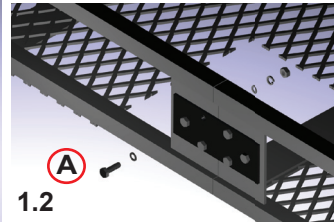

STEP 2

Position the Main Tray Tube underneath the cargo baskets such that the caution sticker will be facing away from the vehicle. Lightly fasten the hitch beam to the cargo baskets using Bolt Assembly B in the center bolt hole. Bolt Assembly B consists of (1) M10 x 80 Bolt, (2) M10 Flat Washers, (1) M10 Lock Washer, and (1) M10 Nut.

Place the two Support Beams underneath the main tube and fasten using Bolt Assembly C (one per support beam). Bolt Assembly C consists of (1) M10 x 90 Bolt, (2) M10 Flat Washers, (1) M10 Lock Washer, and (1) M10 Nut. Tighten the bolt assemblies, but do not over torque. **Note:** *Tray grating has been removed for illustrative clarity only.*

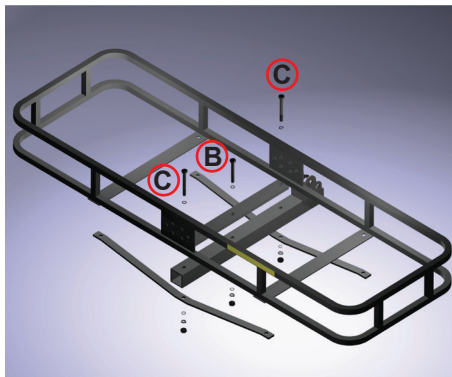

CAUTION The caution sticker must face away from vehicle!

STEP 3

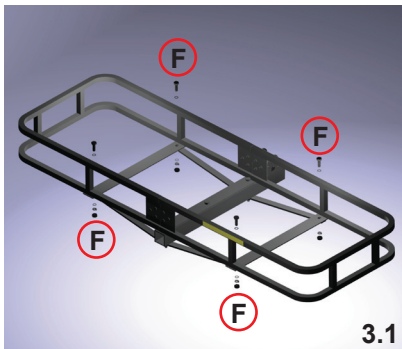

Secure the ends of the support beams using four Bolt Assembly F sets (Figure 3.1). Bolt Assembly F consists of (1) M10 x 30 Bolt, (2) M10 Flat Washers, (1) M10 Lock Washer, and (1) M10 Nut.

Apply the Reflective Stickers to the rear corners of the carrier as shown (Figure 3.2).

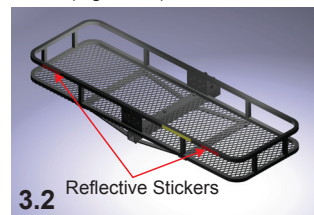

STEP 4

Gather all of the parts shown, which are required for the following steps (Figure 4.1). **Note:** *At this point, the main tray tube should already be attached to carrier.*

Insert the shorter Hitch Tube into the bracket of the main tray tube such that the holes on the rounded end of the hitch tube align with the bottom holes of the bracket (Figure 4.2).

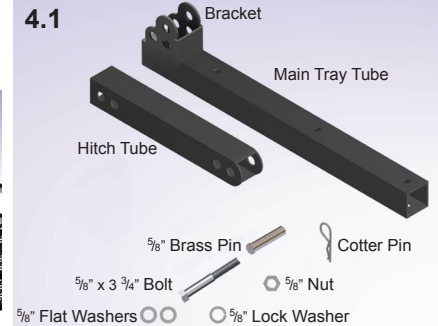
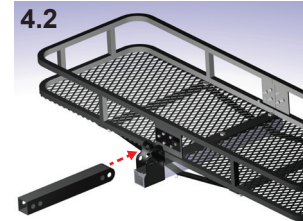

STEP 5

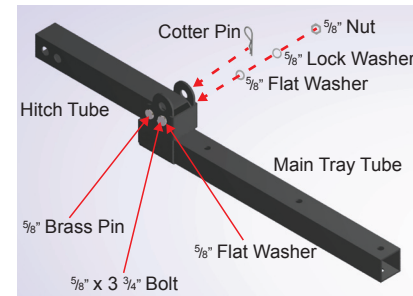

Insert one 5/16" Brass Pin through the aligned holes on the main tray tube bracket and hitch tube furthest from the carrier. Secure with the corresponding Cotter Pin.

Next, insert a 5/16" x 3 3/4" Bolt through the other aligned holes on the main tray tube bracket and hitch tube (the one closest to the cargo basket). Secure with two 5/16" Flat Washers, a 5/16" Lock Washer, and a 5/16" Nut. There should now be one empty set of holes at the top of the main tray tube bracket. **Note:** *Attached carrier not shown for illustrative clarity only.*

FOLDING THE CARRIER

To fold the carrier upright, remove the brass pin from the aligned hitch tube and bracket holes closest to the vehicle (Fig. A).

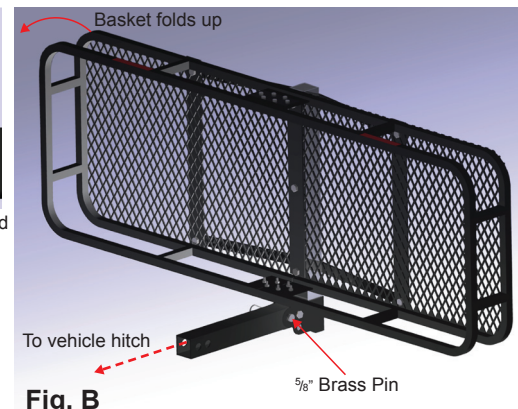
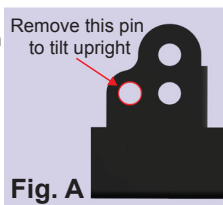

Fold the carrier upwards until the formerly unoccupied holes of the main tray tube bracket realign with the hitch tube holes. Insert the brass pin and cotter pin back into the newly aligned holes of the bracket and hitch tube. This will lock the carrier in place (Fig. B).

Note: *When carrying a spare tire on the back of your vehicle, it is important to know the clearance of the cargo basket. When the carrier is unfolded, the distance from the center of the hitch pin to the edge of the rail is 15". When in the folded position, the distance from the center of the hitch pin to the top edge of the rail is 7 3/4".*